

ESSE

700-SE

Multi-Fuel & Wood Burning Stove

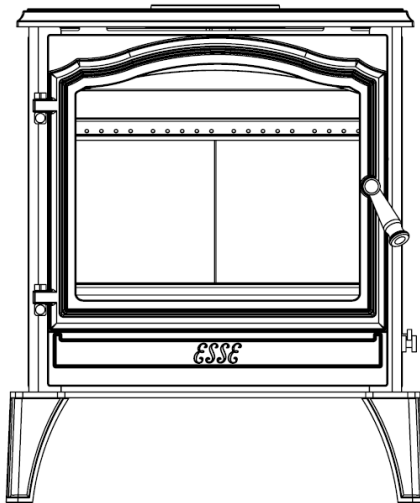

Tested to
AS/NZS 4012/4013 (2014)



CONTENTS

General Safety Notes	P 2	Installing the Stove	P 11
Installation instructions	P 3	Operating Instructions	P 12
Chimney & Flue	P 3	Wood Burning	P 14
Flue Draught	P 6	Solid Fuel Burning	P 16
Flue Stabiliser	P 7	Technical Information	P 17
Dimensions & Clearances	P 7	Maintenance	P 18
Commissioning Checklist	P 10	Guarantee	P 19

GENERAL SAFETY NOTES

- SE Stoves need to maintain a higher flue temperature than a Non-SE Stove. As such it will not shut down like a Non-SE Stove and is designed to continue to draw air in to maintain these temperatures and meet local authority regulations.
- Properly installed, operated and maintained, this appliance will not emit fumes into the dwelling. However occasional fumes from de-ashing and re-fuelling may occur. Persistent fume emission is potentially dangerous and must not be tolerated. If fume emission does persist, open doors and windows to ventilate the room. Let the fire burn out or eject and safely dispose of fuel from the appliance. Once the fire is cold, check the flue and chimney for blockages and clean if required. Do not attempt to relight the fire until the cause of the fume emission has been identified and corrected. Seek expert advice if necessary.
- Do not fit an extractor fan in the same room as the appliance.
- It is important that flue ways are cleaned frequently and the chimney swept regularly. Also the stove must be maintained in good mechanical order. Regular sweeping means at least once a year for smokeless fuel and a minimum of twice a year for other fuels.
- If the chimney was previously used for an open fire, it is possible that the higher flue gas temperatures generated by the stove may loosen deposits that were firmly adhering to the inner surface of the chimney and cause blockage of the fluepipe. We recommend that in such a situation a second sweeping of the chimney should be carried out within one month of regular use of the stove after installation. Also, lock or remove any existing dampers in the flueway.
- Should it be likely that children, aged or infirm people approach the fire, then a fireguard should be fitted.
- Avoid the use of aerosol sprays in the vicinity of the stove when it is in operation.
- This appliance must be installed as per these instructions and regulations complied with. No modifications or alterations of any kind are permitted.

INSTALLATION INSTRUCTIONS

- The installer has a responsibility under the Health and Safety at Work Act 1974 to provide for the safety of persons carrying out the installation.
- Attention is drawn to the fact that fire cement is caustic and hands must be washed thoroughly after use.
- The appliance is heavy and care must be taken during handling.
- Although the appliance does not contain asbestos products, it is possible that asbestos may be disturbed in existing installations and every precaution must be taken.
- All local regulations, including those referring to National and European standards need to be complied with when installing the appliance.



NOTE

The Esse 700SE Free-Standing solid fuel appliance conforms to the requirements of Australian/New Zealand Standard 2918:2001, with respect to floor, ceiling, side wall and rear wall surface temperatures, when tested in the two test positions shown in figure 4c & 4d in accordance with Appendix B of AS/NZS2918:2001.

CHIMNEY& FLUE

The successful operation of this appliance relies on the adequate performance of the chimney that it is connected to.



WARNING

This Appliance is not suitable for installations in a shared flue system.

The chimney must:

- Have an internal cross section of no less than 320cm² (Ø200mm). If a flue liner is used it should be 150mm diameter (6") and suitable for solid fuel.
- Be a minimum 4.5m high from hearth level to pot.
- Be terminated at least 1m above roof level so that the chimney does not terminate in a pressure zone (see Fig. 2).
- Be free from cracks, severe bends, voids and obstructions.
- Be connected to this one appliance only.
- New chimneys must be tested in accordance with HETAS requirements.
- If the stove is installed as a free standing appliance, it should not support any part of the chimney.
- Voids in the chimney should be avoided, as these will prevent a steady flue draught.
- The stove flue pipe should pass beyond the narrowing of the chimney (see Fig. 1).

- A flue/chimney access point may also be required so that the state of the chimney can be checked and any fallen soot removed.
- External flues must be insulated to prevent heat loss.

Fig.1 – Ideal Flue Connections

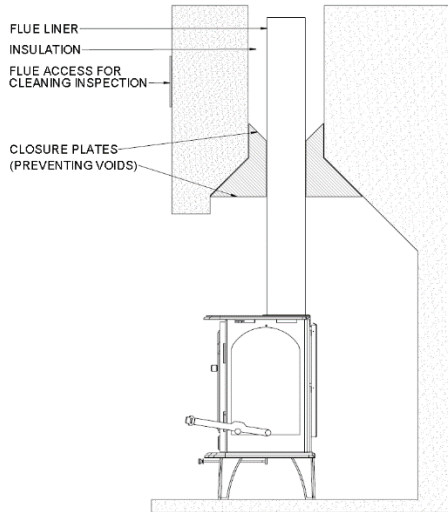

Fig.2 – Chimney and Flue Performance

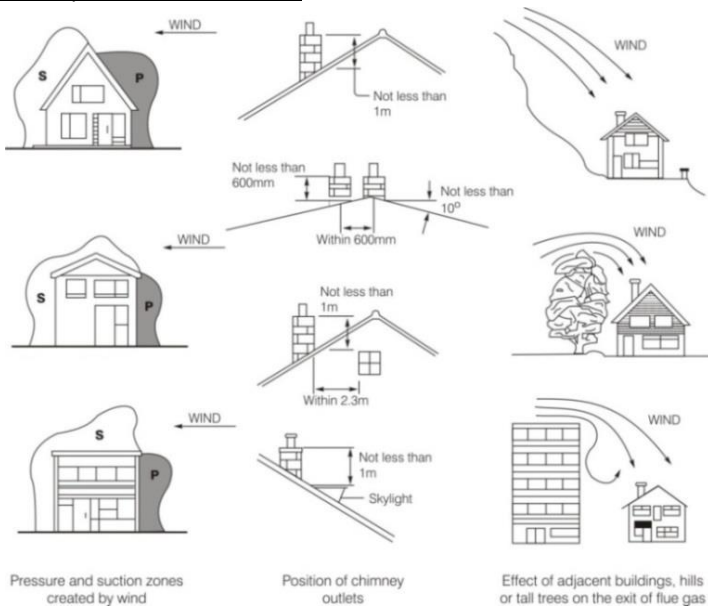

Fig. 3 Wildcat default flue kit



Freestanding Triple Skin Flue Kit Perforated 6" - 8 1/4" - 10 1/4" System

QTY	DESCRIPTION
4	6" Stainless Steel Inner Flue 915mm Long
1	8" Painted Perforated 915mm Long
1	8" Painted Perforated 915mm Long with inside tabs
2	8 1/4" Galvanized Inner Flue Casing 915mm Long
1	10 1/4" Galvanized Notched Outer Flue Casing 915mm Long
1	10 1/4" Galvanized Outer Flue Casing 915mm Long
1	Cowl
1	Ceiling Ring
2	50 x 50 Angles 915mm Long
1	Installation Guide

CARTON SPECIFICATIONS	
Height	460mm
Width	460mm
Length	1150mm
Weight	32kg

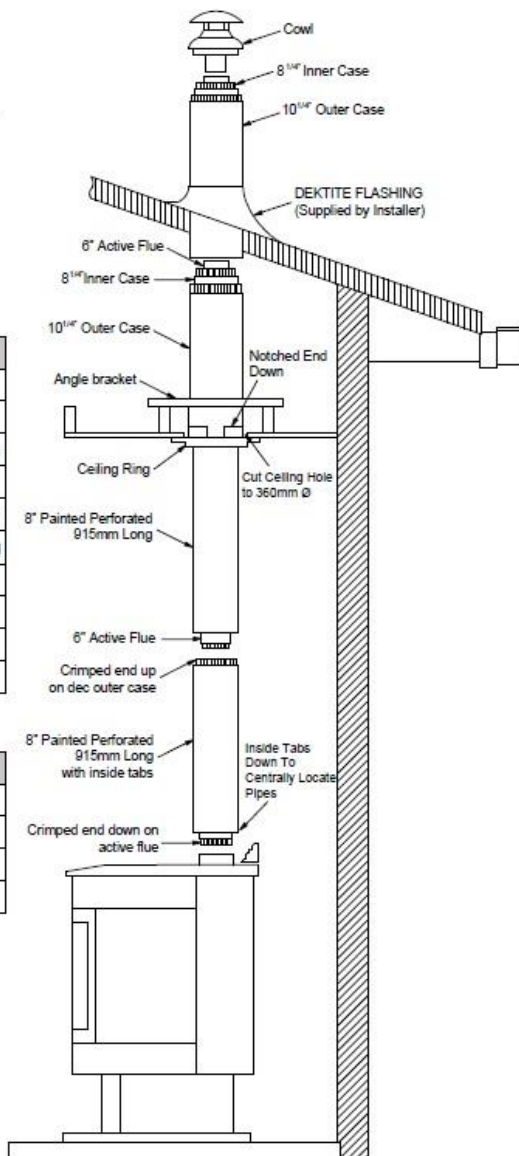

MUST ONLY BE INSTALLED BY AN AUTHORISED PERSON IN COMPLIANCE WITH AS 2918

FLUE DRAUGHT

The chimney can be checked, before the stove is installed, with a smoke pellet. If the chimney doesn't pull the smoke it may suggest the chimney needs attention (see the Flue Diagnosis Table, below).



NOTE

This test is only a guide as an apparently poor flue may improve once the stove is installed, lit and the flue is warmed. If, once the stove is installed, there is any doubt that the chimney is providing an adequate draught; a flue draught reading can be taken with the stove lit. Two flue draught readings should be taken, one with the stove at minimum rate and one at maximum rate.

MEASUREMENTS

The flue draught test hole must be drilled in the flue pipe as close to the stove as possible and before any flue draught stabiliser.

MINIMUM

The stove should be lit and allowed to warm the flue thoroughly. The air controls can then be set so that the stove burns on a low setting. Allow the burning rate to become steady. The flue draught reading should now be taken with the primary air intake closed and the secondary control fully open.

MAXIMUM

The primary air intake can now be opened to allow the stove to burn at maximum rate. Give the stove some time for the burning rate to become steady and then close the primary air intake, make sure the secondary control is fully open and take a flue draught reading immediately. Ideally, the flue draught reading should range between 1mm wg (10 Pa) and 2.5mm wg (25 Pa). Any readings significantly outside this range may indicate the need for remedial action.

Low flue draught symptoms: difficult to light and smoke coming into the room.

CAUSE	REMEDY
Cold chimney	<i>Line the chimney</i>
Chimney too short	<i>Extend the chimney</i>
Down draught	<i>Relocate/extend chimney terminal. Fit an anti-down draught cowl</i>
Chimney diameter too large	<i>Line the chimney</i>
Chimney obstruction	<i>Clear/sweep the chimney</i>
Restricted air supply	<i>Check for competing draughts (other chimneys, extractor hoods/fans). Fit an air vent if the room is sealed.</i>

High flue draught symptoms: fire difficult to control, fuel will not last, stove too hot, stove damage, chimney fire.

CAUSE	REMEDY
External wind conditions combined with chimney terminal	<i>Fit stabiliser cowl. Fit flue draught stabiliser.</i>

FLUE STABILISER

A flue stabiliser can be fitted to reduce the draught through the stove if the flue draught is too high. The flue stabiliser should be:

- Fitted in the same room as the stove.
- The same size as the flue pipe.
- Fitted no closer than 700mm to the flue outlet of the appliance.

DIMENSIONS & CLEARANCES

Fig.4a – Stove Dimensions, Standard leg configuration.

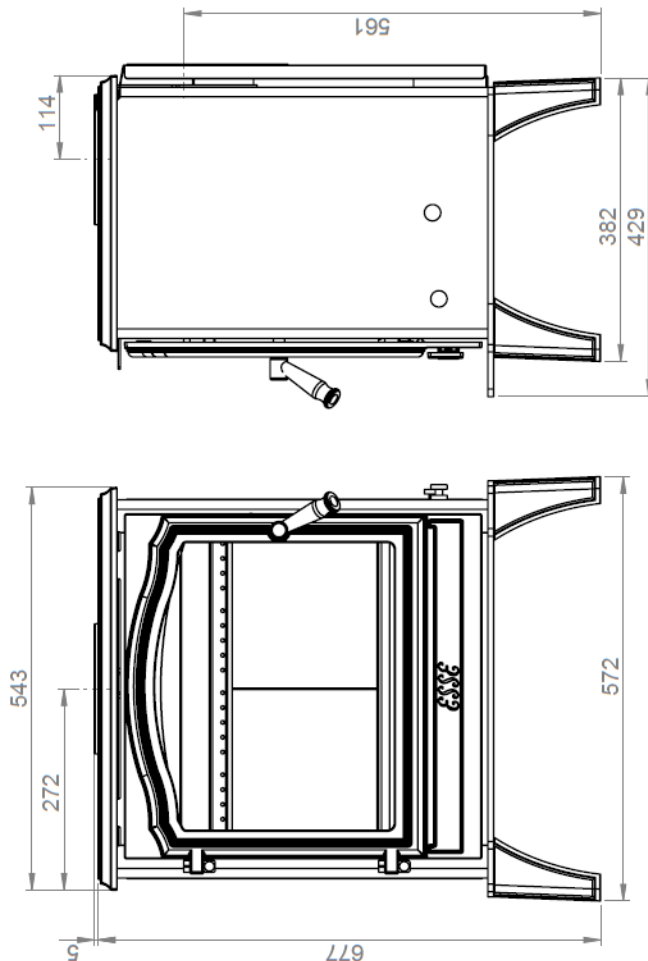
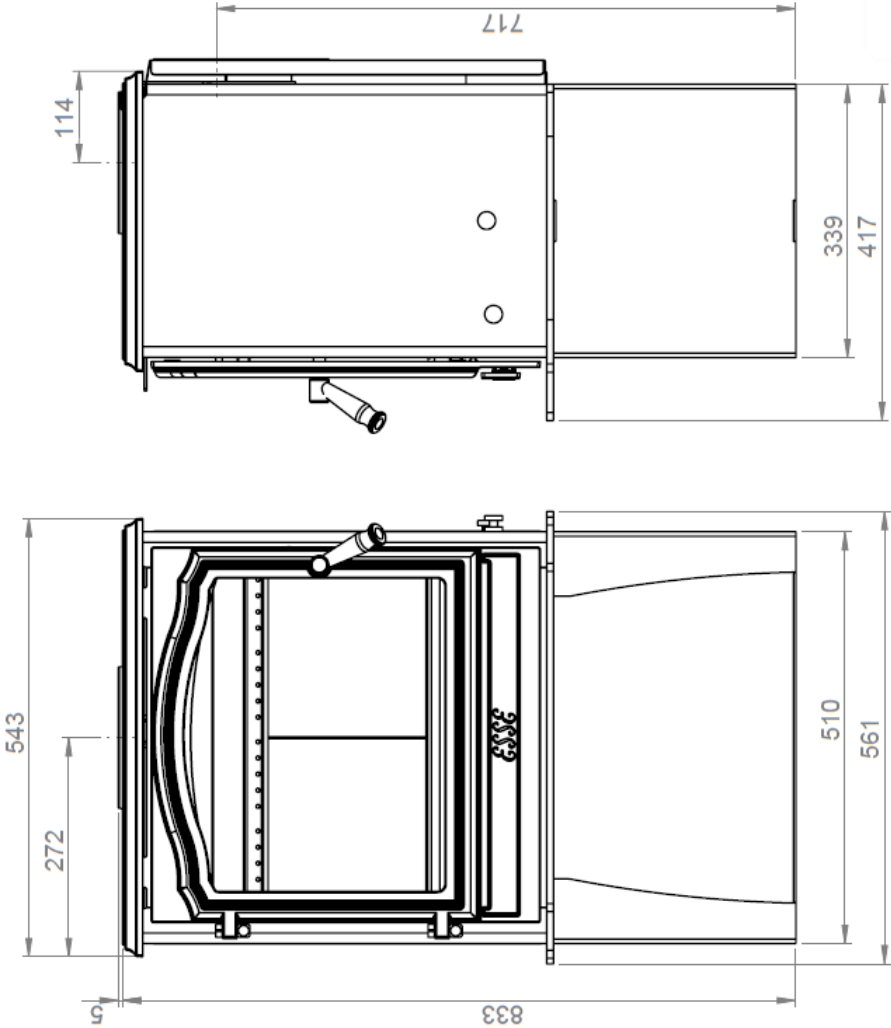

Fig.4b – Stove Dimensions, Log store configuration.



The Esse 700-SE was tested in two positions, conforming to Australian & New Zealand standard 2918:2001 Appendix B.

The diagrams below show the tested clearances for this appliance.

Fig.4c-Position A – Parallel position.

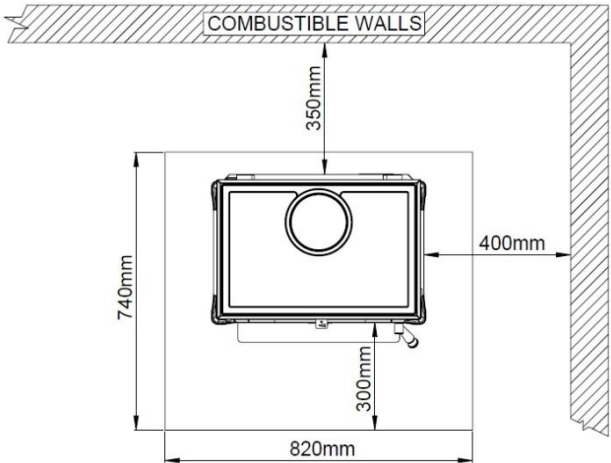
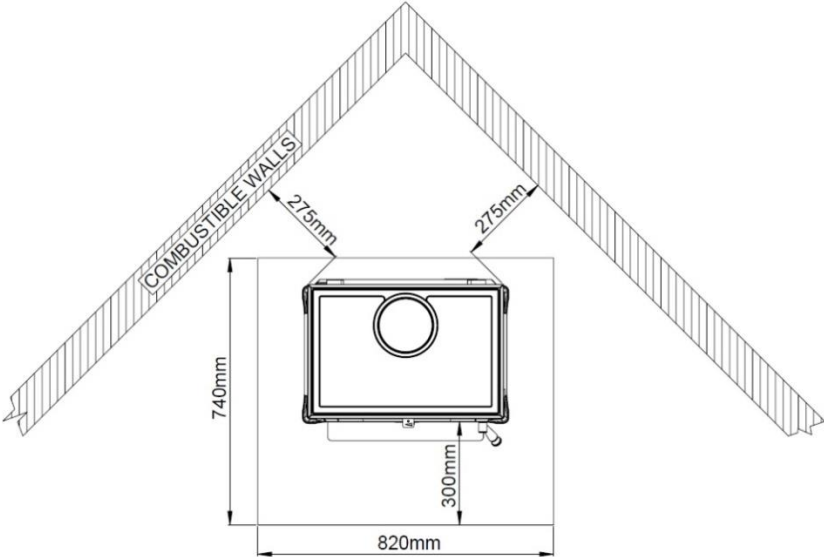

Fig.4d-Position B – Corner position.



COMMISSIONING CHECKLIST

To assist with any potential guarantee claim please complete the following information:-
To be completed by the installer.

Dealer the appliance was purchased from:

Name:

Address:

Telephone No:

ESSENTIAL information:

Date Installed

Model Description:

Serial No:

Installation Engineer:

Company Name:

Address:

Telephone No:

Commissioning Checks – to be completed and signed:

Is the flue system correct for this appliance?	Yes	<input type="checkbox"/>	No	<input type="checkbox"/>
Flue swept and checked for soundness?	Yes	<input type="checkbox"/>	No	<input type="checkbox"/>
Smoke test completed on installed appliance?	Yes	<input type="checkbox"/>	No	<input type="checkbox"/>
Spillage test complete?	Yes	<input type="checkbox"/>	No	<input type="checkbox"/>
Has the use of the appliance, operation and controls been explained?	Yes	<input type="checkbox"/>	No	<input type="checkbox"/>
Clearance to combustible materials checked?	Yes	<input type="checkbox"/>	No	<input type="checkbox"/>
Instruction book handed to the customer?	Yes	<input type="checkbox"/>	No	<input type="checkbox"/>
CO Alarm fitted?	Yes	<input type="checkbox"/>	No	<input type="checkbox"/>

Signature:..... Print Name:.....

INSTALLING THE STOVE

INSTALLING THE AIR INLET CONNECTION

Ventilated air may be supplied directly from the outside via a 3"/ \varnothing 80.0mm heat resistant pipe connected to the rear of the stove.

Fig. 5 – Outside Air Connection

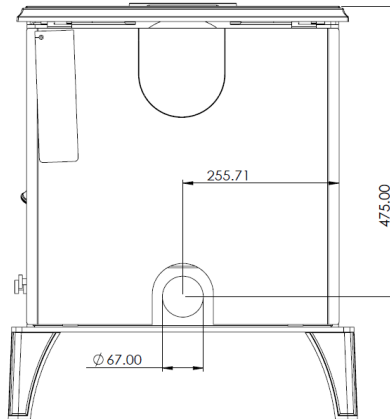

POSITIONING

The overall dimensions of the stove are shown in Fig. 4c & 4d along with a table that indicates recommended distances between the stove and surrounding combustible materials. As a rule, any surrounding combustible material should not exceed 80°C. There should be sufficient space around the stove for service work.

HEARTH

A minimum of 740mm x 820mm x 9mm thick floor protector should be used underneath the appliance. The floor protector should extend 300mm in front of the appliance fuel loading door with the stove being placed centrally in the 820mm width. The Thermal Conductivity of the floor protector should be a minimum of 0.1m² K/W for 9mm sheets.

FLUE CONNECTION

The flue pipe used to connect the stove to the chimney is 150mm (6") in diameter. This stove is only available as a top flue connection.

IMPORTANT INSTALLATION NOTES

1. The installation must allow for adequate chimney sweeping.
2. Avoid using bends greater than 45° to the vertical. All flue pipe sections should be as close to vertical as possible.
3. All joints in the flue system must be effectively sealed.
4. All flue sockets must face upwards.
5. Check the appliance for soundness of seals between castings and main components and that all supplied parts and fittings are correctly fitted.

On completing the installation, check that all the internal components of the stove are positioned correctly.
Check - Ashpan, iron grate, baffle, side and back bricks.



Leave the appliance operational and explain the operation of the stove to the customer. Leave all instructions and operating tools with the customer.

OPERATING INSTRUCTIONS

Figure 6 shows the stove and its controls.

Additional loose parts supplied inside your stove include:

- A Stove Mitt – For removing the ash pan, adjusting the primary air controls, adjusting the air wash control and operating the door handle.
- A Riddling Tool – For operating the riddling grate and lifting the ash pan in and out.



WARNING

Over firing will damage your stove.
To maintain peak efficiency, your stove should burn approximately 2.2kg of well-seasoned wood per hour.

Fig. 6 – Stove Controls

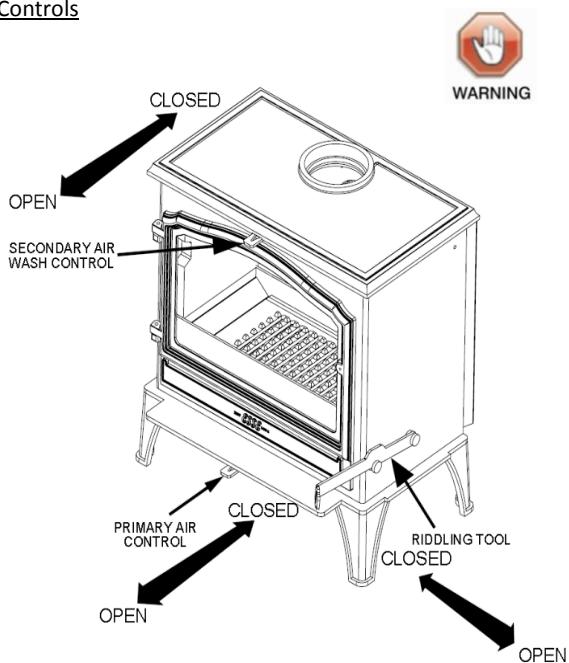

Always use stove mitts when adjusting controls and opening or closing the door.

Fig. 7-Riddling Grate Open

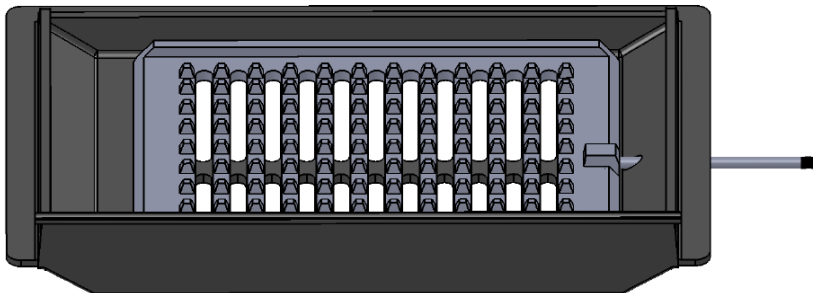
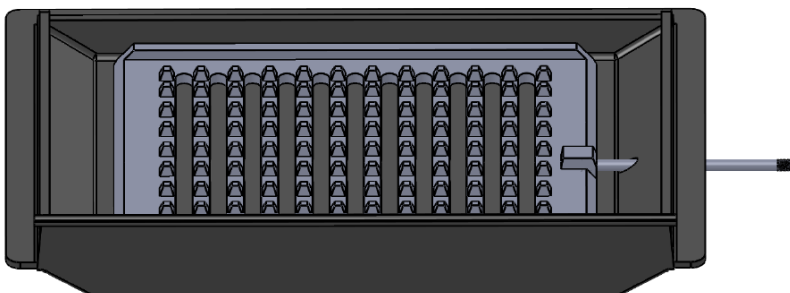

Fig. 8-Riddling Grate Closed



Your stove should not be used as an incinerator and only recommended fuels shall be used.



Parts of the appliance, especially the external surfaces, will be hot to touch when in operation and due care will need to be taken.

RE-FUELLING ON TO A LOW FIRE BED

If there is insufficient burning material in the fire bed to light a new fuel charge, excessive smoke emission can occur. Refuelling must be carried out onto a sufficient quantity of glowing embers and ash that the new fuel charge will ignite in a reasonable period. If there are too few embers in the fire bed, add suitable kindling to prevent excessive smoke.

FUEL OVERLOADING

The maximum amount of fuel specified in this manual should not be exceeded, overloading can cause excess smoke.

OPERATION WITH DOOR LEFT OPEN

Operation with the door open can cause excess smoke. The appliance must not be operated with the appliance door left open except as directed in the instructions.

DAMPERS LEFT OPEN

Operation with the air controls or appliance dampers open can cause excess smoke. The appliance must not be operated with air controls, appliance dampers or door left open except as directed in the instructions.

WOOD BURNING

LIGHTING & CONTROLLING THE FIRE

For wood burning it is best to set the riddle grate to the closed position, see fig. 7.

Before lighting the fire for the first time ensure that the baffle, side and back bricks and all the internal components are in position. Burning without either will result in the stove overheating and being damaged. Open the secondary control and the primary air control fully. Place some tightly rolled paper on top of some crumpled paper on the base towards the back of the stove. On top of this, place some small pieces of wood. Light the crumpled paper and close the door. Once the fire becomes established add some larger pieces of wood. As the stove comes up to temperature close the primary air control using the stove mitt. The burning rate of the stove can now be regulated by the rate at which fuel is added and by adjusting the secondary control.

With the above in mind it is plain to see that the stove should ideally be run with the primary air inlet closed and the secondary control open whenever possible. Another advantage of running the stove with the secondary open is that the air that is being drawn into the stove travels across the glass forming an air barrier between the glass and the fire bed helping to prevent smoke particles sticking to the glass.

If the fire dies down too low, opening the primary air control for a short period will revive it. When reviving a low fire it is important to also use kindling before adding larger logs to help prevent smoke.



NOTE

Wood burns most efficiently when the air for combustion is supplied from above the fire bed rather than below. The air supplied above the fire bed provides the oxygen necessary for the volatile gases (smoke), given off by the wood as it heats to combust. This ensures that the gases are burnt and used to heat the stove instead of being wasted up the chimney or condensing and forming tarry deposits inside the stove, in the flue or on the stove glass. Running the stove with the primary air control open and the secondary control closed will provide oxygen for the wood to burn on the fire bed but will not provide air for the volatile gases above the fire bed to combust resulting in a smoky inefficient fire.

ASH REMOVAL

Only remove small amounts of ash from the firebox. When de-ashing, leave 30-40mm depth of ash in the bottom of the firebox for the best performance. Always use the stove mitt to open and close the door.

CORRECT RUNNING TEMPERATURES FOR BURNING

To get the best results from your stove it is recommended that a wood stove thermometer (available from your stove dealer) be fitted to the flue pipe above the stove, at eye level if possible. The figures below show the recommended temperature of the flue gases:

115°C – 245°C (240°F – 475°F)

The flue gases should be in this temperature band for the safest, most efficient and most economical operation of your stove.

Below 115°C

This is below the condensation point of wood gases and may cause the build-up of tar in the chimney, dirty the stove glass and result in the inefficient burning of the fuel.

Above 245°C

Too hot. Heat will be wasted up the chimney. Excess heat may damage the stove or ignite any existing accumulation of tar resulting in a chimney fire.

EXTENDED BURNING

Loading a large amount of wood into the stove all at once will reduce the temperature inside the stove. If the temperature is too low, the gases given off from the wood will be too cold to combust resulting in a lot of smoke covering the inside of the stove, including the glass, with soot. To combat this problem it is a good idea to increase the temperature of the stove before loading by further opening the air inlets. Load the wood and leave the air controls open until the moisture is driven out of the wood and the stove is back up to an efficient operating temperature. The air inlets can then be reduced to hold the temperature of the stove. Loading the stove little and often will help keep the stove temperature steady. When loading wood, make sure that the end grain of the wood in the stove is pointing away from the glass, otherwise the moisture and gases coming from the end grain of the wood will dirty the glass.

TYPES OF WOOD FOR FUEL

For best results use well-seasoned hardwood such as Oak, Ash or Beech. Allow wood to dry out under cover in well-ventilated conditions for at least twelve months. As a rough guide wood is ready for burning when radial cracks appear in the end of logs. Properly dry wood means it should have a moisture content of between 15%-20% which can only be accurately measured using a moisture meter. Burning wood that is not seasoned will result in tar being deposited in the stove, on the glass and in the flueways. This build-up of tar is a hazard and if it ignites may cause a chimney fire. Resinous softwood burns well and gives a high output for short periods but is not as efficient and does not last as long as hardwood.

RE-FUELLING

Adding a 'little fuel often' is the best re-fuelling method to keep smoke to a minimum. Our tests have shown that burning logs not longer than 20cm and with a width or diameter of no more than 12cm will produce the optimum smoke free performance.

PEAT

Peat is a fuel conveniently available in some areas and should be burned in the same manner as wood.

SOLID MINERAL FUEL BURNING

LIGHTING AND CONTROLLING THE FIRE

For solid mineral fuel burning it is best to set the riddle grate to the open position, see fig. 6.

Before lighting the fire for the first time ensure that the baffle, the riddling grate and the side and back bricks are in position. Burning without either will result in the stove castings overheating and being damaged.

Open the secondary control and the primary air control fully. Place some tightly rolled paper on top of some crumpled paper on the base towards the back of the stove. On top of this, place some small pieces of wood and on top of that a few small pieces of mineral fuel. Light the crumpled paper and close the door. Once the fire becomes established and the fuel is burning, more fuel can be added. When the stove is hot and the fuel is no longer producing smoke, the secondary control can be reduced. The burning rate of the fire can now be controlled with bottom air slider. As air from the primary air slider flows up through the grate it will cool the grate preventing it from overheating and becoming damaged. Reducing the air inlet and introducing air only from the secondary control will allow the fuel to burn but the grate will not be cooled resulting in damage to the grate. When controlling the fire, the air inlet should be altered gradually. Reducing the primary air dramatically and all at once on a hot stove will cause the fuel to clinker and will result in a build-up of gases and smoke which could ignite with a bang the moment air is reintroduced.

EXTENDED BURNING

Before adding a large amount of fuel, the grate should be de-ashed and the ash pan emptied. Add the fuel sloping it from the front coal bar up to the back of the stove to the level of the top of the back brick. Open the primary air inlet and let the fire burn for a period on high rate in order to hit the stove back up to temperature and drive off the moisture and gases in the fuel. If a lot of smoke is produced on reloading, the secondary control can be opened further to keep the smoke back from the glass. As the fire gets back up to the temperature, reduce the secondary control and reduce the primary air inlet to suit the burning rate. The exact setting of the air controls depends on a number of variables including: the flue draught, the fuel used and the installation and so the best setting for your stove can only be learned by experience.

ASH REMOVAL

The level of ash should not be allowed to build up to the level of the grate. If the level of ash becomes too high the air through the grate will become restricted causing the grate to overheat and preventing the fuel from burning efficiently. Shake the riddling grate to de-ash the grate. The ash is then able to pass through the grate slots into the ashpan. The ashpan should be emptied on a regular basis, however when wood burning we recommend leaving 30-40mm depth of ash in the bottom of the firebox for the best performance.

MINERAL FUELS

Ordinary bituminous house coal is not recommended and must not be burned in smoke control areas. Burning bituminous house coal will result in a sooty stove and chimney, and the stove glass will require cleaning regularly. There are numerous natural anthracites and manufactured smokeless fuels that will burn cleanly and have more reliable burning characteristics. A list of these fuels and their suitability is produced by HETAS (www.hetas.co.uk). Consult your local fuel merchant to find out what is available in your area. Petro coke should not be used as it burns very hot and may damage the stove casting.



NOTE

The above text should be used as a guide only. The ideal operation of your stove depends on a number of factors, which vary with each installation, and so gaining experience operating your stove is the only way to learn its best operation.



NOTE

The stove as with any other metal products will expand and contract. A ticking noise may occur. This is normal for this type of appliance.

TECHNICAL INFORMATION

Appliance approximate weight: 99kg

Primary Air Settings	Average Power (kW)	Efficiency (%)	Particulate Emission Factor (6/kg) Oven Dry Wood
High	9.5	64	0.9
Medium	6.3	57	0.9
Low	5.6	70	1.2

When tested the appliance particulate emissions factor was 1.0g/kg of Hardwood fuel that complies to AS/NZS4014.1 and the average efficiency of the appliance for all burn rates is 64%.

MAINTENANCE

CLEANING THE STOVE

The stove should only be cleaned when it is cold. The exterior can be dusted with a firm brush. Do not use a cloth, as this will drag on the paint finish leaving lint on the surface. From time to time it may be necessary to renovate the exterior by repainting. High temperature stove paints in aerosol form are available at esseaustralia.com.au or from your stove dealer. Do not use this form of paint until the stove is cold and always read the instructions on the container before starting to paint. The door glass is made of a special heat resisting ceramic and may be cleaned when cold with proprietary glass cleaning liquids and a dry cloth.

ACCESSING THE CHIMNEY



NOTE

Cleaning chimneys can be hazardous and should be carried out by a professional.



NOTE

The chimney should only be accessed for cleaning when the stove and flue are cold.

The flue can be access when the stove is un-lit and cold, by opening both stove doors and removing the top baffle. To do this you must lift the baffle and rotate so that it can be removed on an angle through the door. Re-install by reversing the removal procedure.

SHUTTING DOWN THE STOVE (LONG TERM)

The following procedure should be followed if the stove is not to be used for a long period, summertime for instance. Remove all the ashes from the grate and ash pan and use a vacuum cleaner nozzle to clean ash from the base of the stove. Remove the baffle plate and brush the flue ways. Close the door and open the air inlets fully. This action will allow air circulation through the flue ways and help avoid corrosion and condensation.

SERVICING

Regular maintenance should be carried out by a competent engineer.

GUARANTEE

CONDITIONS OF GUARANTEE

Your ESSE is guaranteed against defects arising from faulty manufacture for 2 years when supplied by an ESSE Specialist.

Upon registration of the warranty, ESSE will extend the guarantee period to 5 years from purchase. Your details must be registered with us by either returning the completed warranty card or by completing registration online at esseaustralia.com.au. To qualify for the 5 year warranty, the unit must be registered within 1 month of installation.

The appliance must be only used for normal domestic purposes and in accordance with our instructions, be correctly installed and serviced.

The guarantee does not cover:

Installation

Wear and tear

Parts deemed to be replaceable or service parts including electrical components that may be replaced during the normal usage of the appliance.

Enamel damage caused by impact, spillage, water ingress or condensate attack from flue or by using unsuitable fuels.

This guarantee is personal to the original purchaser and not transferable.

Any stove or defective part replaced shall become the Company's property

HOW TO PROCEED WITH A COMPLAINT

If you have cause for dissatisfaction with your stove, you should first contact your ESSE dealer, who will bring your concerns to our attention. We will assess the nature of the complaint and either send replacement parts for your dealer to fit, or arrange for an ESSE engineer to inspect the appliance and carry out any work that may be deemed necessary. If the fault is not actually due to faulty manufacture but some other cause i.e. misuse, failure to install correctly, or failure to service at regular intervals, a charge will be made to cover the cost of the visit and any new parts required.

SPARE PARTS

Only genuine ESSE spare parts are recommended. Parts that may need occasional replacement are:

Fire bricks

Ash pan

Fire grate

Mitt

Baffle



**Distributed in Australia by
Paul Agnew Design PTY LTD**

**Phone +61 (0) 440 139 705
Online www.esseaustralia.com.au**